

User manual

Smart Lift



Model/type:

SL 1008 OUTDOOR GIANT - 2.72 hp



SmartGlass
LIFTER

2121 South Priest Drive, Suite 115 | Tempe, AZ 85252

480.236.9255 | info@smartglasslifter.com

<https://smartglasslifter.com>

Table of contents

Introduction	3
EC Declaration of Conformity	4
Transport/handling/operating for the first time/storage	5
Maintenance	5
Technical data, safety regulations	6 - 7
Overview/General description.....	7 - 8
How to use the vacuum/suction function	9
How to operate the arm and yoke.....	9
Electrical functions, vacuum gauges and safety switches.....	10
Charger and battery box	11
Base of the machine.....	12
Switches and alarms.....	12 - 13
Remote control unit for arm and yoke	14
Special warnings.....	15
Troubleshooting breakdowns on Smart LIFT GIANT, Battery charger	16 -19
Motor and gears – various component parts	20 - 21
Load diagram.....	22
Electrical table	23 - 24
Diagram vacuum function	25
Diagram hydraulic function.....	26
Diagram for hydraulic manifold	27
Battery charger	28

Introduction

Congratulations on your new SL 1008 OUTDOOR GIANT.

Smart LIFT products are designed and built for safety.

However, there are certain functions in any machine that are impossible to make completely safe. We have therefore compiled a list of safety regulations which appear as warnings in this instruction manual.

Please read the safety regulations on the following pages before you start using SL 1008 OUTDOOR GIANT. Think about how you can ensure that the warnings and safety regulations are observed in daily operations.

Yours sincerely,



2121 South Priest Drive, Suite 115 | Tempe, AZ 85252

480.236.9255 | info@smartglasslifter.com

<https://smartglasslifter.com>

EC Declaration of Conformity



The manufacturer responsible for the technical

dossier:

Smartlift A/S

N.A. Christensensvej 39

7900 Nykøbing Mors, Denmark

declares herewith that

the following machine: Lift

Model/type: **SL 1008 OUTDOOR GIANT – 2.72 hp**

Serial no.: _____ Production month: _____ YEAR: _____

is manufactured in compliance with the following EC Directives:

- Machinery Directive 2006/42EC
- Low Voltage Directive 2006/95/EC + 2014/35/EU
- EMC Directive 2014/30/EU

The following standards are applied:

DS/EN ISO 12100-1:2009	(Safety of machinery – general principles)
DS/EN ISO 12100-2:2009	(Safety of machinery – general principles)
DS/EN ISO 4413:2010	(Hydraulic general regulations and safety requirements for systems and their components)
DS/ISO/TR14121-2:2012	(Risk assessment guidance and methods)
DS/EN 13857:2008	(Safety of machinery – Hazard zones and safety distances)
DS/EN ISO 3691-5:2009	(Pedestrian-propelled trucks)
DS/EN 13155/A1+A2:2009	(Cranes – Safety – Non-fixed load lifting attachments)
DS/EN 60204-32:2008	(Electrical equipment of machines – Part 32: Requirements for hoisting machines)

Date:

Transportation/handling

The Smart LIFT OUTDOOR GIANT is suitable for indoor and outdoor use, although the machine should not be exposed to heavy rain or snow.

Before transporting the machine, switch off electronic parts at the main switch.

Attach Smart LIFT firmly to a vehicle/trailer and protect the machine from direct rain and snow.

NEVER lift a Smart LIFT using forks (forklift truck or similar).

Before operating for the first time

Before operating the machine for the first time, insert vacuum hoses and fully recharge the battery.

Storage

Always switch off Smart LIFT at the main switch before storing. Store in a dry place.

The batteries should always be fully charged.

Maintenance

By law lifting devices must undergo a mandatory service inspection at least once a year. The service inspection should preferably be performed by the manufacturer and always in accordance with the manufacturer's instructions.

There are lubrication nipples on the machine close to the steering unit and on all the hydraulic cylinders. Nipples must be greased regularly.

Hydraulic fluid and pressure filter must be replaced at each service inspection.



Hydraulic tank and pressure filter



Pressure filter

Technical data

Total height	61 in
Total width	39.8 in
Total length	129.9 in
Net weight	2204,6 Lb
Weight blocks	661.4 Lb
Total weight including weight blocks	2866 Lb
24 V DC	
Charger 110 V 60 Hz 25 A – US plug	

Safety regulations

Regular use

The Smart LIFT may only be operated by an operator who has been specially trained in the use of the machine and its safety functions.

Before using the machine, the operator should check that there are no loose parts on the machine as these represent a risk of damage and danger.

WARNING! Vacuum!



It is dangerous to operate the machine if any of the safety measures, vacuum gauges or audible alarm are defective. NEVER lift a load if the visual and audible alarm is triggered. NEVER lift wet or slippery items using the suction pads.



WARNING! Danger of tipping!



The machine must ALWAYS stand on firm ground/flooring and the supports must ALWAYS be correctly in place. The load must ALWAYS be centred on the lifting arm. Drive carefully when a load is attached to the suction pads. Drive carefully over uneven ground. The extension arm must be fully retracted. During manoeuvring, ALWAYS ensure that the lifting height is as low as possible.



WARNING! Potentially explosive!



The machine must NOT be used in an ATEX zone. (explosive atmosphere).





DANGER!

Standing under the load during lifting is strictly prohibited.



PROHIBITED!

Must NOT be used to lift people. Only the operator is permitted to remain in the immediate vicinity of the machine while it is operating.

PROHIBITED!

The machine must NOT be used during charging.

Overview/general description



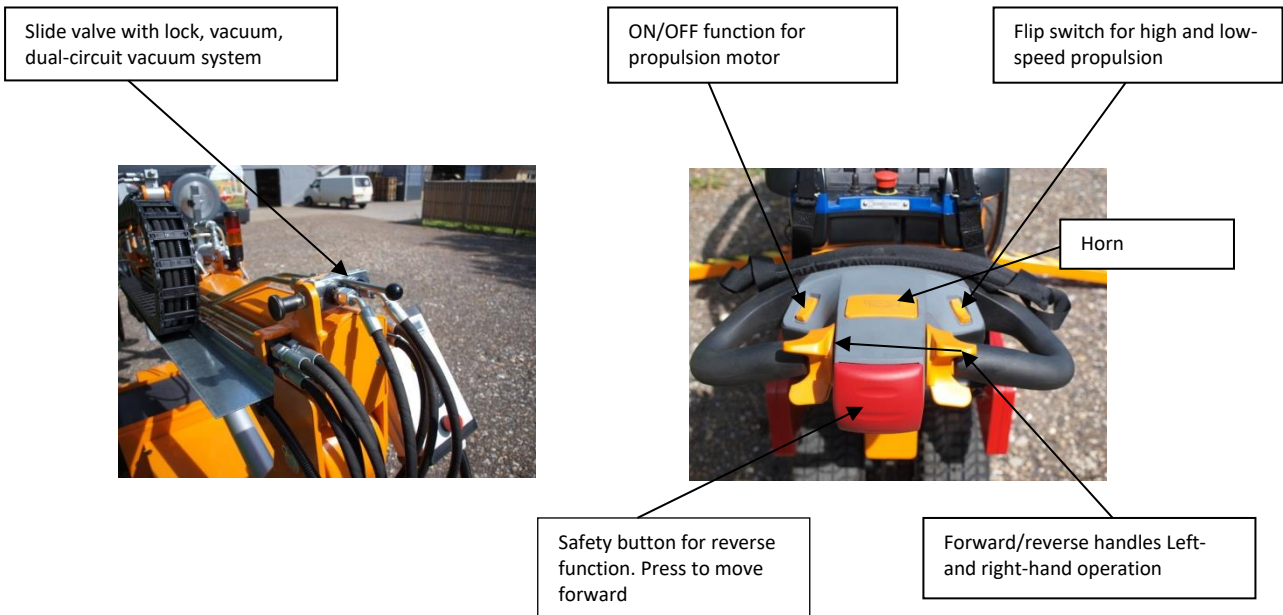

IMPORTANT!!!

DURING TRAVEL, THE SUPPORTS MUST BE IN THE CORRECT POSITION TO PREVENT TIPPING.

BEFORE LIFTING AT HEIGHT, THE SUPPORT SPINDLES MUST BE FIRMLY ATTACHED TO FIRM GROUND/FLOORING.

How to operate the VACUUM function

There is an ON/OFF vacuum function. The vacuum pumps are controlled by two vacustats.

Both vacuum pumps are adjusted by means of the vacuum vacustats to stop at 8.99 psi pressure.

The vacuum function is operated by a slide valve and safety pin, attached to the top of the telescopic extension arm. To apply suction, press the slide valve in. To release **suction**, pull out the safety pin and pull back the slide valve.

Control unit for telescopic arm and lifting yoke

It is important that the operator has read the following description of the function so that he or she knows precisely how the machine works.

Smart LIFT is manually operated. The machine has six functions for moving the arm and yoke. Each can be operated individually.

RAISE/LOWER function:

This function moves the arm up or down. This is a hydraulic function.

TIP function:

This function tips the load horizontally/vertically. This is a hydraulic function.

TELESCOPIC function:

A hydraulic cylinder on the telescopic arm controls extension/retraction.

YOKE SWIVEL function:

A hydraulic cylinder at the end of the lifting arm controls yoke swivel movements.

YOKE TIP function:

A hydraulic cylinder between the yoke and the arm controls yoke tip movements.

LATERAL SHIFT function:

A hydraulic cylinder between the two front wheels controls the lateral shift movement.

Electrical functions

STOP/EMERGENCY STOP function:

The emergency stop button is located on the vacuum manometer gauge and battery indicator control panel. The button shuts down vacuum, hydraulic, electrical control and propulsion motor.

MAIN SWITCH:

Located on the right-hand side of the machine close to the battery box. Turn handle to power down all electrical functions.

PROPULSION MOTOR:

To activate the propulsion motor, flip the ON/OFF switch on the steering unit. To steer, use the handles on the left- and right-hand sides of the steering unit.

FORWARD/REVERSE function:

Flip switch UP to move forwards. Flip switch DOWN to reverse.

SAFETY function:

To stop the vehicle and move forward, activate the safety switch.

Vacuum gauges and safety switch

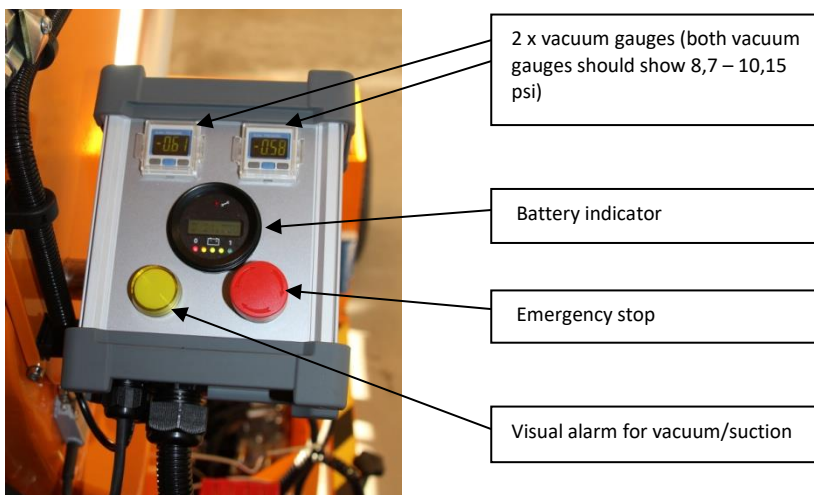

Charger

The machine must NOT be used during charging.

24 V Battery charger under the machine's cover plate. For instruction of the charger, look at page 28.



110 V connector

Main switch for all electrical functions



Battery box



4 x 12 V batteries – serial and parallel – connected for 24 V voltage

In the event of a breakdown, there is a fast troubleshooting table inside the battery box.

Bottom of the machine



Switches and alarms

SL 1008 Outdoor Giant is fitted with a Faber CLG SR Load Limiter.

When overloaded during lifting, the following will occur:

90 % overload: Yellow warning light flashes. The lift is close to overload.

100 % overload: Red warning light flashes and audible alarm sounds – The lift can only retract the telescopic arm until the overload is eliminated.



There are 2 x red emergency stop buttons on the machine.



CE-approved plug for battery charger

Main switch and removable key

Remote control unit for arm and yoke

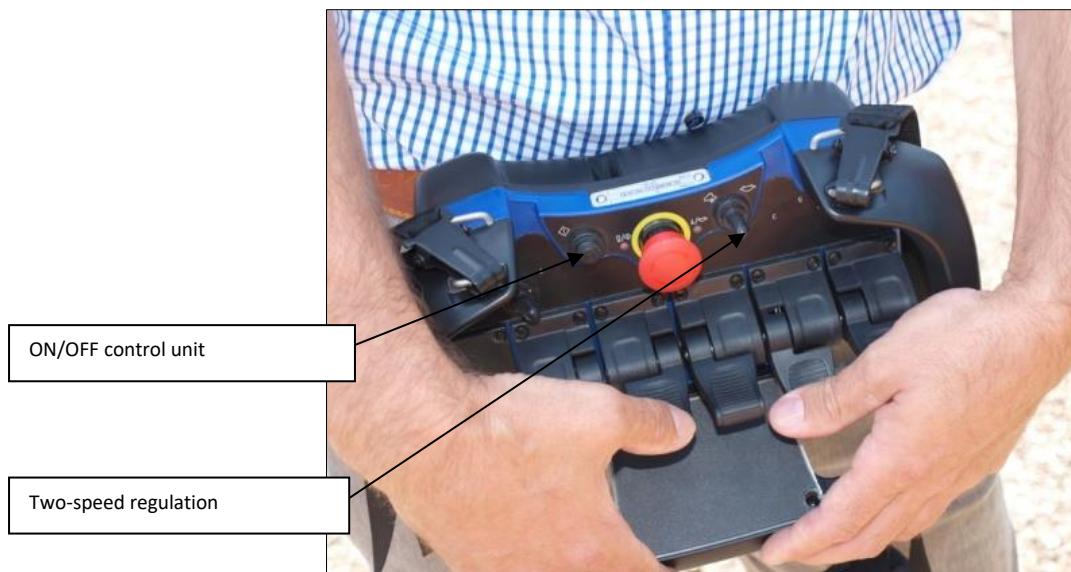

ON/OFF control unit

Two-speed regulation

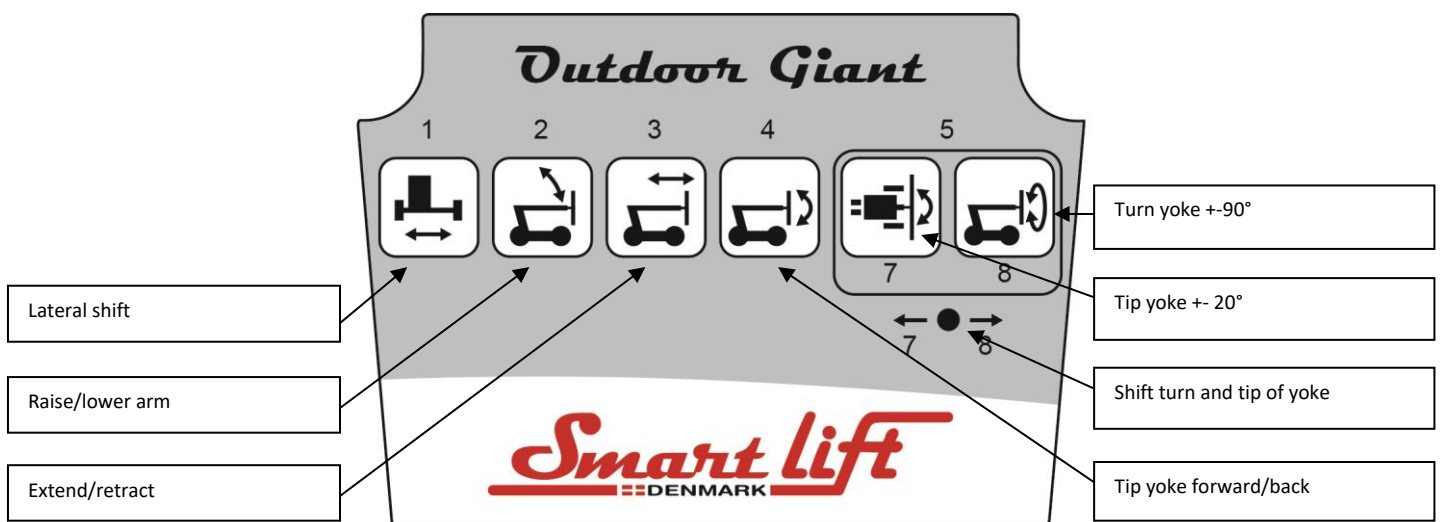

Lateral shift

Raise/lower arm

Extend/retract

Turn yoke +/-90°

Tip yoke +/- 20°

Shift turn and tip of yoke

Tip yoke forward/back

- ✓ The remote control unit can be removed from the steering unit so that the operator can operate the machine from a distance.
- ✓ Make sure that the remote control unit battery is fully charged at all times.
- ✓ Don't forget to press the control unit ON/OFF button before operating the lifting device.
- ✓ Check that the emergency stop button is in the correct position before starting the lifting device.
- ✓ Important: Always wear the control unit strap over your shoulder to avoid dropping the control unit.
- ✓ **Important: When using the control unit at a distance from the lift, check the lift position to avoid hazardous occurrences due to inappropriate lifting.**

NB: When operating OUTDOOR GIANT:



The telescopic arm MUST be fully retracted.

The load MUST be centred on the yoke.

**WHEN TRAVELLING, THE SUPPORTS MUST BE EXTENDED.
DRIVE WITH CARE OVER ANY TYPE OF GROUND.**



Supports at both sides prevent the machine from tipping over.

**WHEN LIFTING AT HEIGHT, THE SUPPORTS MUST BE EXTENDED
AND THE SPINDLES FIRMLY ATTACHED TO FIRM
GROUND/FLOORING.**

Troubleshooting breakdowns

In the event of a breakdown on SL 1008 OUTDOOR GIANT, check the following first:

- Does anything appear to be broken or is there anything unusual about the machine? Are there any unusual noises?
- Are the batteries charged and is the main switch ON? (To read battery level on the battery indicator, the ON/OFF button on the propulsion handle must be ON (lit))
- Has one of the emergency stop buttons shut down the machine?
- Has the CLG SR Load Limiter disconnected the machine due to overloading?
- Are the hoses intact and attached correctly?

Troubleshooting and remedial action will be divided into **three main categories:**

1. **Vacuum** (the machine's suction capacity)
2. **Movements controlled from the remote control unit** raise/lower lifting yoke, extend/retract telescopic arm, tip and turn yoke, lateral shift of the machine (hydraulic functions).
3. **Propulsion controlled by the regulating handles** – Drive forward/reverse the machine.



1. Vacuum system failure



Slide valve with safety lock pin to activate and deactivate vacuum/suction

Vacuum/suction level on both vacuum gauges must be about -8,99 psi (between -8,7 and -10,15 psi)



If – the vacuum pump does not work.

Always check that the machine is powered up. Check that the power is not switched OFF at a switch or by a fuse in the control box. The pump circuit may also be faulty.

If – the vacuum pump is running all the time.

Check that the vacuum slide valve is closed (must be closed to create a vacuum). Read vacuum gauge (must be at about -8,7 psi)

If – vacuum gauge reading is about or exceeds -10,15 psi all the time.

There is an fault on the vacuum regulator

If – vacuum gauge reading is about or less than -7,98 psi all the time, when the pump is working.

One of the pumps is faulty or there is a leak in the hose connection between the non-return valve and the vacuum pump

If – the vacuum gauge reading falls as soon as the main switch is switched OFF and the slide valve is closed. There is an fault/leak between the slide valve and the non-return valve. Vacuum gauge, slide

valve or vacustat may be faulty. Disconnect hoses at connectors: If the pressure continues to fall, the slide valve is faulty.

If, when applying suction to the load, the vacuum pump starts and runs continuously, possibly at falling pressure levels, when the slide valve opens.

Check that all the suction pads are correctly aligned with the load, i.e. check that the individual suction pad is parallel with the load and that no part of the suction pads extends beyond the edge of the load (IMPORTANT!).

If – the vacuum pump starts and stops at very short intervals.

Disconnect the spiral hoses at the connectors and close the slide valve (if this is not already closed). If the vacuum pump continues to start and stop at very short intervals, the non-return valve may be faulty.

If – the vacuum pump starts and stops at very short intervals, possibly with falling pressure in one or both vacuum gauges when the slide valve is opened after successfully applying suction to the load.

Close slide valve. Disconnect one vacuum circuit at the hose connector and then open the vacuum slide valve again. If the vacuum pressure reading on the vacuum gauge for the disconnected circuit remains at -8,7 psi, there is a fault in the hose set or suction pads in the disconnected vacuum circuit. Follow the same procedure to check for a fault in the other vacuum circuit system. Listen for possible leaks.

2. Breakdowns in *movements* controlled via the control unit

The battery is flat – needs recharging.

The emergency stop button is activated.

The ON/OFF button is affected



Hydraulic/electrical control fault – do the following: Read off error code and call Smart LIFT Service or your Smart LIFT dealer.

For a list of dealers, click:
www.smartlift.dk



3. Propulsion section failure

If – there is no response when regulation handles are activated.

Check that the main switch is ON – turn clockwise to switch to ON. Is the ON/OFF flip switch on the steering handle in the ON position? Are the batteries charged (check indicator)?



Battery charger for wireless control unit

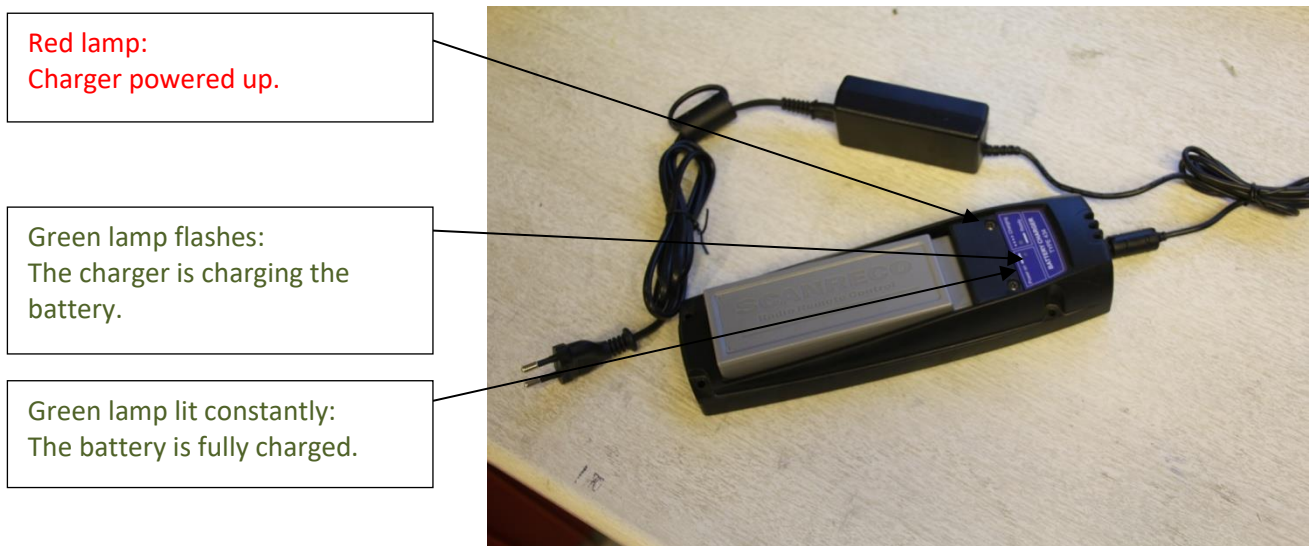

Motor and gears



Various components

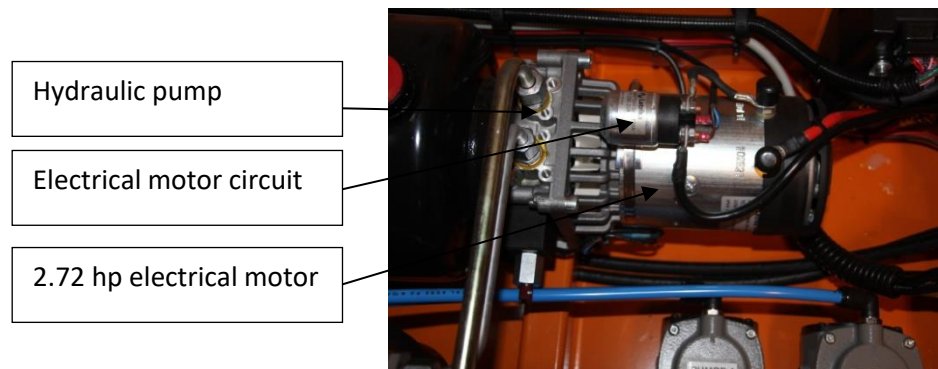
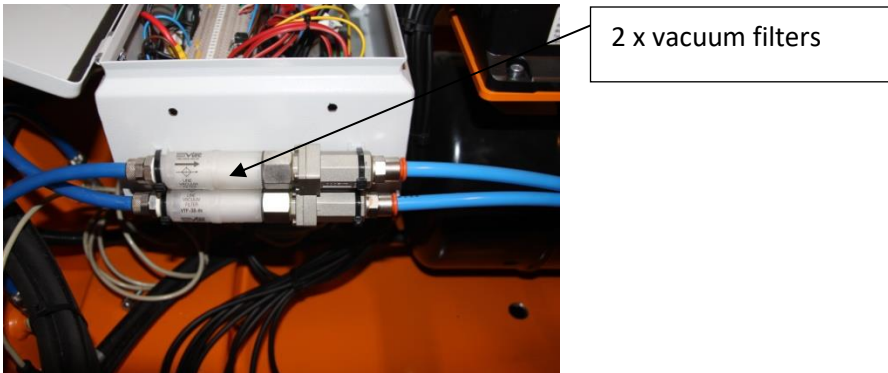



Motor control unit



2 x vacuum pumps



Lateral shift cylinder

Load diagram SL 1008 Outdoor Giant

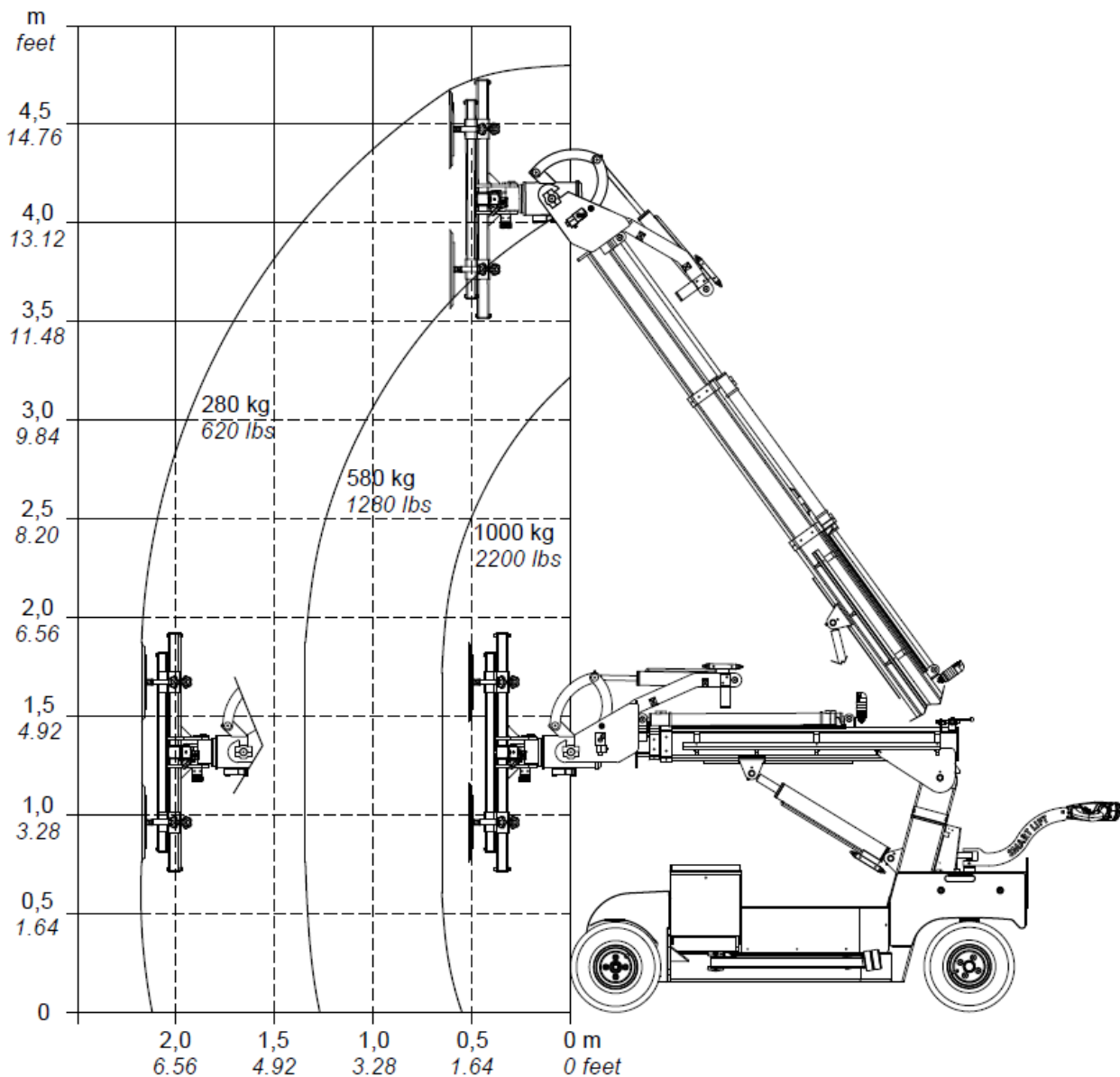

- ✓ NEVER expose the lifting device to loads in excess of those stated in the load diagram (above).
- ✓ Ensure that the lifting device is on a stable and level surface – this is especially important when hoisting at height.
- ✓ Attach the load centrally to the yoke.
- ✓ Avoid oblique lifts as these place excessive strain on the machine.
- ✓ Be aware of the danger of crushing when lift functions are activated.
- ✓ Make sure no unauthorised persons stand close to the lift when it is operating/running.
- ✓ Take care – avoid exposing yourself and others for dangers when operating the lift.

Electrical diagram

Pilot current to circuits	Pump 1	1	Diode to no. 3	
	Pump 2	2	Diode to no. 4	
Audible alarm in junction box	Red	3	Brown vacuum lamp in instrument panel	
		4		
Horn	Brown	5	Blue + from steering/horn switch	
	free	6	free	
Hydraulic pump bypass	Brown +	7	DV1/Bypass + (Scanreco)	
	Blue -	8	DV2/Bypass - (Scanreco)	
Hydraulic motor circuit	Brown +	9	EX2.3 Start circuit (Scanreco)	
	Blue -	10	EX2.5 Negative - (Scanreco)	
6/2 shift valve on arm	Brown +	11	EX2.4 6-way valve (Scanreco)	
	Blue -	12	EX2.10 Negative (Scanreco)	
Top switch	Brown +	13	EX2.8 Top switch (Scanreco)	
From propulsion motor	Brown	14	J.13 Red/blue	Motor control
	Blue	15	J.5 Thick pink	
	Yellow	16	J.8 Thick green	
	Green	17	J.7 Thick black	
	Pink	18		
	Grey	19	J.32 Red/green	
	Red	20	J.26 Brown	
	White	21	J.31 Grey/blue	
From control	Yellow	22	J.24 Yellow/red	
	Brown	23	J.11 Pink	
	White	24	J.33 Pink/black	
	Grey	25	J.16 Grey/black	
	Red	26	Green + from emergency stop	
	Green	27	J.1 Thick red	
Programming connector	Green	28	J.22 Purple/red	
	(Pink) Black	29	J.29 Green	
	Blue	30	J.7 Black (jumper from no. 17)	
	Red	31	J.28 Blue	
Extension switch on arm	Yellow	32	J.25 Red	
	Black	33	Cable 1. Extension switch (Faber-com)	
Instrument panel/lamp	Brown	34	Cable 2.	
	Grey	35	Cable 1. +	
	Yellow	36	Cable 2. - 90 % load	Lamp (Faber-com)
		37	Cable yellow/green - 100 % load	
	free	38	free	
	free	39	free	
	free	40	free	

Instrument panel

Red + from junction box	Emergency stop	Green to terminal 26
-------------------------	----------------	----------------------

Yellow - from junction box	Vacuum - lamp	Brown to terminal 3
----------------------------	------------------	---------------------

Grey + from junction box White - from junction box Blue signal	Battery - indicator	
--	------------------------	--

Blue + Black - = yellow lamp Brown - = Red lamp	Lamp to overload	Brown to terminal 35 Grey to terminal 36 Yellow to terminal 37
---	------------------------	--

Cable 1 Cable 2	Top switch	Red + from junction box Blue to terminal 13
--------------------	---------------	--

Red + to emergency stop
 Green + return from emergency
 stop to term. 26
 Yellow - Lamp to vacuum
 Brown + Lamp to vacuum
 Grey Battery indicator pin 5
 White Battery indicator pin 6
 Blue Battery indicator signal pin 8

Vacuum System

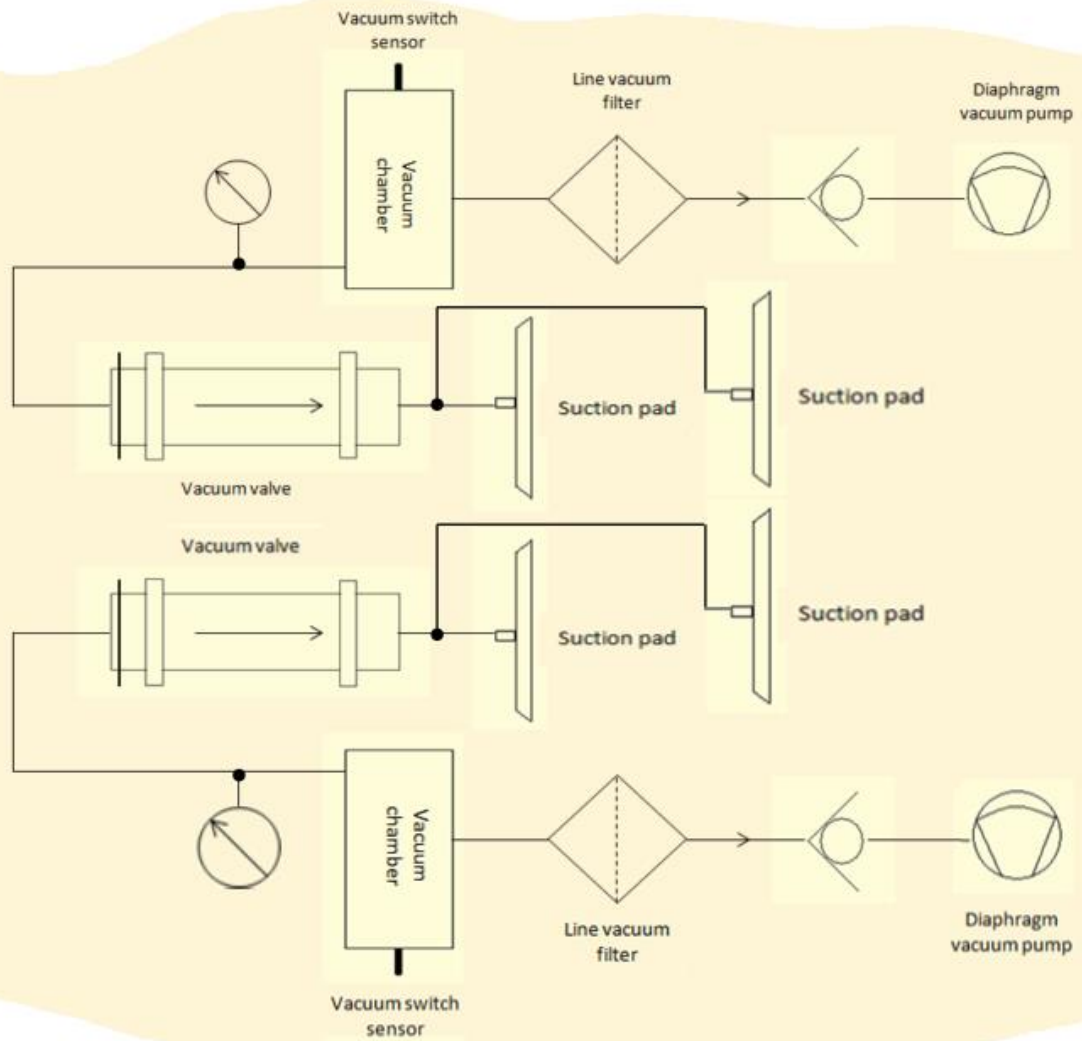

Hydraulic diagram

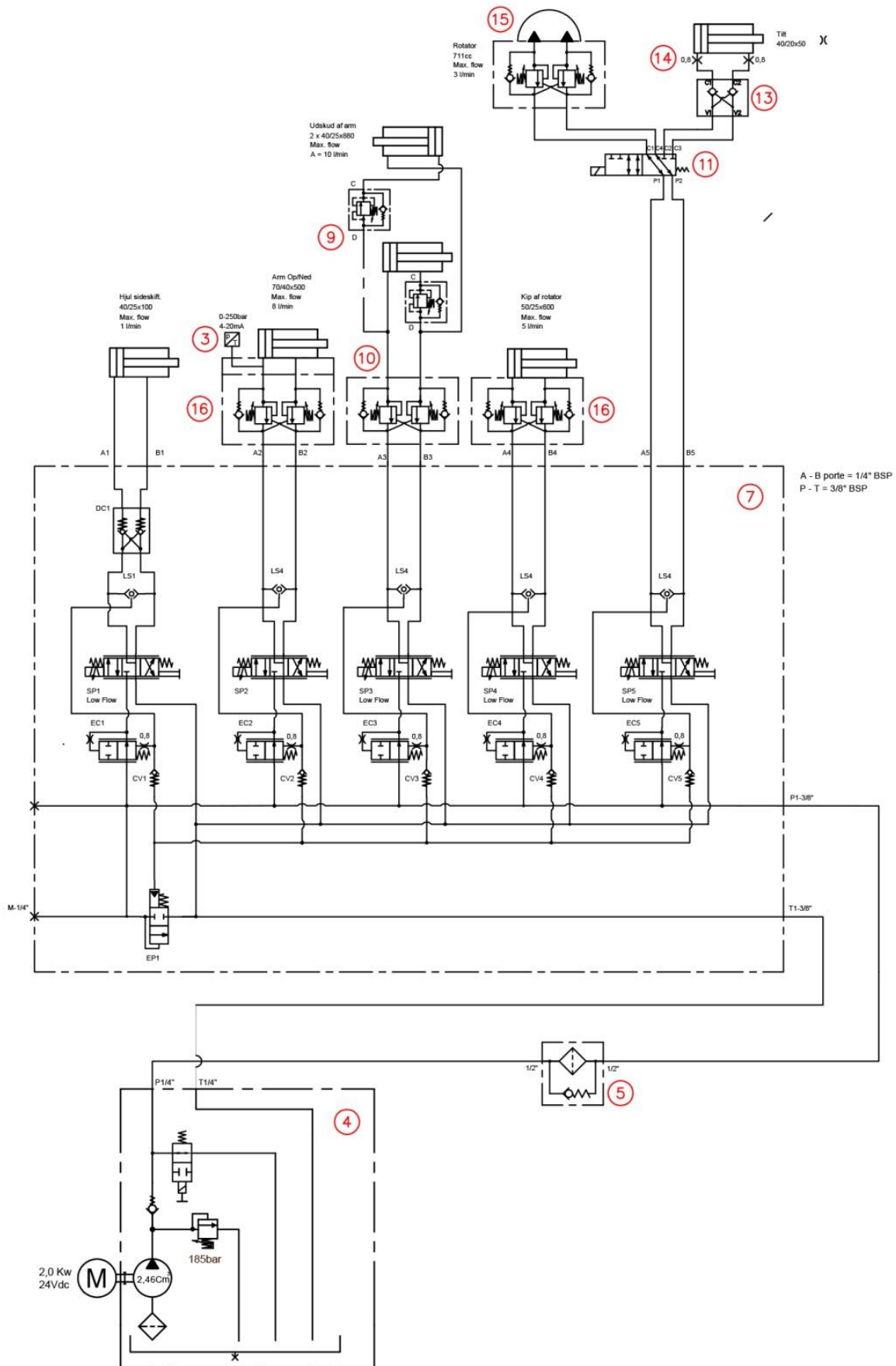

Battery charger HF24-25

Understanding Advanced Diagnostics.

Advanced Diagnostics is used when displaying Error Conditions. It will display a series of blink sequences that help you identify the cause of the error and potential solutions.

All Error Conditions are displayed with the Error LED and Standby LED flashing back and forth. The number of flashes between each pulse denotes a potential Error Condition (except reverse polarity and low-voltage battery).

Error	Reason/Solution
Single Flash	Battery will not hold a charge. Have battery checked by a professional.
Double Flash	Possible battery short. Have battery checked by a professional.
Triple Flash	Battery voltage is too high for the selected charge mode. Check the battery and charge mode.
Quadruple Flash	Abnormal AC grid power: VAC <85V or >250V, or Frequency <45Hz or >65Hz.
Error LED Solid Red	Reverse polarity. Reverse the battery connections.
Standby Solid Orange	Battery voltage is too low for charger to detect. Verify connection and mode selection, if still not working use Supply Mode to raise battery voltage.